

Second Exam.
CM416
Jan. 30, 1995

1. **A Recycle System.** Suppose the temperature in the reactor is described by

$$\frac{dT'}{dt} = -3T' + q' + \alpha 4T'_r$$

where T' is the deviation reactor temperature, $0 \leq \alpha \leq 1$ is the recycle ratio, q' is the deviation heat/cool input variable and T'_r is the temperature of the recycle stream. Further, suppose the recycle stream temperature undergoes a first order process described by

$$\frac{dT'_r}{dt} = 2(T' - T'_r)$$

Assuming zero initial conditions for all the deviation variables and their derivatives,

- (a) (10 pts) Obtain the closed loop transfer function from $\bar{q}'(s)$ to $\bar{T}'(s)$, i.e. find $G_{cl}(s)$ in

$$\bar{T}'(s) = G_{cl}(s)\bar{q}'(s)$$

(Note: this equation does not involve T_r explicitly because T_r is in the feedback loop.)

- (b) (15 pts) What is the maximum value of recycle ratio, α , for the system to remain stable ?
(This question implies that a chemical plant can become unstable due to effects of recycles.)

2. **Stabilization.** The temperature in an exothermic reactor is described by

$$10 \frac{dT}{dt} = T' + 2q'$$

where T' is the deviation reactor temperature, q' is the deviation heat/cool energy input. Assume the initial conditions including derivatives are zero.

- (a) (10 pts) Obtain the transfer function from $\bar{q}'(s)$ to $\bar{T}'(s)$ and show that this system is unstable.
- (b) (10 pts) Draw a negative feedback control block diagram using a proportional control, assuming the actuator and sensor transfer functions are both 1.
- (c) (10 pts) What minimum value of proportional gain K_c is needed to stabilize the system from $\bar{T}'_{set}(s)$ to $\bar{T}'(s)$?

3. **Cascade Control.** A cascade control configuration is sometimes used to separate different objectives of feedback control. For instance, an inner loop can be used to first stabilize the process and then an outer loop can be used to control the output to track set point and reject disturbances. An example of a cascade control setup is shown in Figure 1. The process transfer function, $G_p = (-s + 1)/(s - 3)$, is unstable.

- (a) (15 pts) Determine the maximum range of K_{inner} values for which the inner loop will be stable, i.e. such that the transfer function from $\bar{x}(s)$ to \bar{y} is stable.

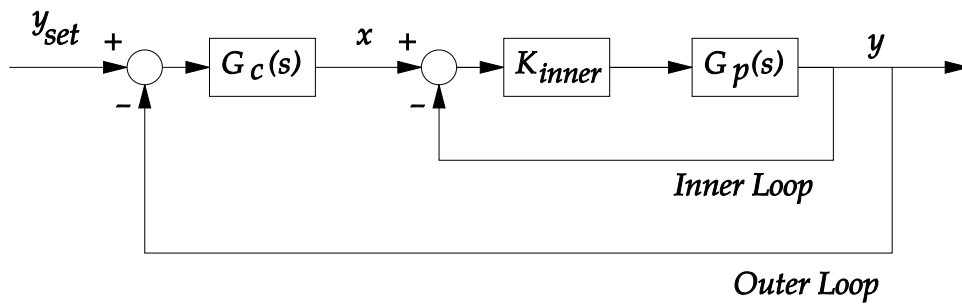

Figure 1: Cascade Control System.

- (b) (20 pts) By letting $K_{inner} = 2$, and $G_c(s)$ be a PI control with $K_c = -1/4$ and $\tau_I = 10$, will the transfer function from $\bar{y}_{set}(s)$ to $\bar{y}(s)$ be stable ?
4. (10 pts) Solve the following differential equation for $x(t)$ using the method of Laplace transforms:

$$\frac{d^2 x}{dt^2} + \frac{dx}{dt} + x = e^{-t}$$

5. (Bonus: 10 pts) Show that the Laplace transform of $f(t) = te^{-at} \sin(\omega t)$ is given by

$$\mathcal{L}[f(t)] = \frac{2(s+1)\omega}{[(s+a)^2 + \omega^2]^2}$$